

# COMPACTA

## **ROBOPAC® STRETCH BANDER**



Ideal for Banding and Spiral Wrapping a Variety of Products Using Stretch Film.

### **ADVANTAGES:**

- Stretch film always hold the products together versus string, strap and tape which do no stretch.
- Stretch film does not damage the products like string, strap and tape might.
- Safe and simple operation.
- Cycle starts with foot pedal.
- Automatic clamping and cutting.
- Product coverage can be total spiral wrap or bands only.
- Film tension easy to adjust with thumb screw.
- Built tough for rugged durability.
- Minimum maintenance is necessary.
- Field proven technology.

**Call or write for details and pricing.**



— **ANOTHER INNOVATIVE PACKAGING SOLUTION FROM** —



*Distributed by:*

2475B Satellite Blvd • Duluth • GA 30096-5808 • USA  
Phone: (678) 473-7896 • Toll Free: (866) 713-7286 • Fax: (678) 473-1025

[www.aetnagroup.com](http://www.aetnagroup.com)

**SALES - SERVICE - PARTS - SHOWROOM**



## TYPICAL APPLICATIONS

- Wood products, such as wood moldings, firewood, tool handles, etc.
- Aluminum and plastic extrusions and tubings.
- Products banded to corrugated supports, such as appliance components, electric motors, sinks, lamps, etc.
- Building materials, such as lumber, windows, framework, etc.
- Textiles and carpets.
- Unitizing of boxed and bagged products to eliminate expensive corrugated cartons.
- And many other products traditionally unitized with string, strap and tape.

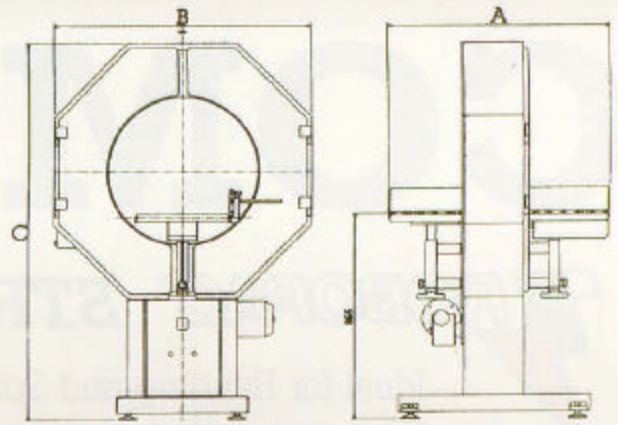

## TECHNICAL FEATURES

- Belt driven rotation unit.
- Number of wraps adjustable from 3 to 5.
- Continuous operating cycle by foot-control.
- Film delivery system with frictioned roller (for constant film tensioning).
- Pneumatically operated cutting and clamping unit.
- Std. voltage: 110 V. Single phase 60 Hz cycles
- Installed power: 1 HP, 6A
- Air consumption: .01 cmf
- Air pressure: 90 psi

## FILM SPECIFICATIONS

- Film width: 2"-3"-4"-5"
- Max. spool diameter: 7-7/8"
- Core Diameter: 3"

Model #	A in. (mm)	B in. (mm)	C in. (mm)	D lbs (kg)	Max rotation speed.
<b>400</b>	37" (930)	34" (860)	54" (1370)	430 (195)	150 r.p.m.
<b>620</b>	37" (930)	40" (1070)	62" (1580)	510 (230)	110 r.p.m.
<b>960</b>	37" (930)	55" (1400)	75" (1910)	595 (270)	70 r.p.m.

### COMPACTA IS AVAILABLE IN MODS "400-620-960"

The dimensions of the cross-sections width and length of products to be bundled on each machine are the coordinates of the points included between the outlines of the diagram referring to specific machine model.

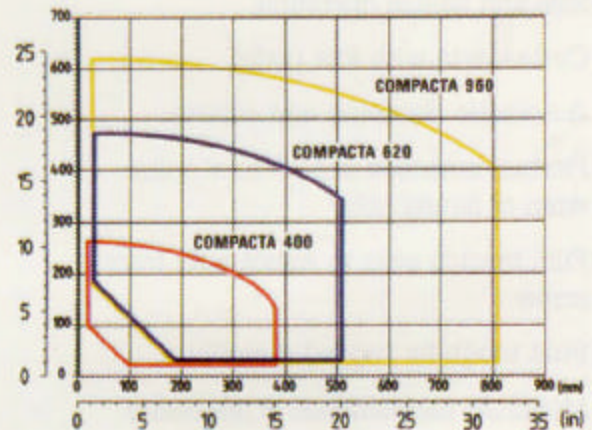

Technical Specifications May Vary Without Prior Notice.

ROBOPAC is also a leading manufacturer of automatic and semi-automatic Platform Stretch Wrappers, Horizontal Spiral Wrappers and Banders.  
Call AETNA GROUP toll-free for complete details.



2475B Satellite Blvd • Duluth • GA 30096-5808 • USA  
Phone: (678) 473-7896 • Toll Free: (866) 713-7286 • Fax: (678) 473-1025

[www.aetnagroup.com](http://www.aetnagroup.com)

**SALES - SERVICE - PARTS - SHOWROOM**