

Pneumatic combination, Tension-Weld® & Strap Cutter /Plastic

Pneumatic Tension-Weld

Pneumatic Tension-Weld® combination tools perform the complete operation of tensioning and sealing Contrax®, Dymax®, or Tenax® plastic strapping without metal seals. A filter-regulator-lubricator assembly (Part No. 173111) and 3/8" diameter air hose are required for proper operation and tool protection.



**VXL-2000Z
VXM-2000Z**



**VXT2-16
VXT2-19**

Pneumatic seal-feed combination tools

Pneumatic combination tools are designed for more demanding, continuous operations. These tools can help speed strapping and maintain consistent strap tension with reduced operator effort.



**AMPT-12
AMPT-58**

Strap cutter



Model 2
Part No. 006630
Cuts tightly imbedded strap. For use with heavier grades of plastic strapping.

Tension-Weld® tool specifications

Model	Part Number	Applied Tension	Tool Type	Strap Type	Joint Type	Seals Used	Strap Take-up	Base Length Under Strap		Power Source	Recommended Air Hose	Dimensions					
								inch	mm			inch	mm	inch	mm	lbs	kg
VXL-2000Z	306540	Up to 200 lbs.	Pneumatic Combination	Dymax 302, 304, 306 Contrax HD719, HD723, HD729, 816, 818; Tenax 1716, 1718, 1818, 1822	Sealless Tension-Weld	N/A	Unlimited	5	127.0	Air	Part No. 008737 10' x 1/4" (3.0m x 6.4mm)	14	355.6	5-1/2	139.7	8.3	3.8
VXM-2000Z	306541	Up to 200 lbs.	Pneumatic Combination	Dymax 304, 306 Contrax HD723, HD729, 816, 818 Tenax 1716, 1718, 1818, 1822	Sealless Tension-Weld	N/A	Unlimited	5	127.0	Air	Part No. 008737 10' x 1/4" (3.0m x 6.4mm)	14	355.6	5-1/2	139.7	8.3	3.8
VXT2-16	422580	Up to 500 lbs.	Pneumatic Combination	High-Strength Tenax 2030, 2038B, 2040	Sealless Tension-Weld	N/A	Unlimited	3-1/2	88.9	Air	Part No. 008558 10' x 3/8" (3.0m x 9.5mm)	15-1/8	384.2	5-5/8	142.9	9	4.1
VXT2-19	422585	Up to 800 lbs.	Pneumatic Combination	High-Strength Tenax 2225	Sealless Tension-Weld	N/A	Unlimited	3-1/2	88.9	Air	Part No. 008558 10' x 3/8" (3.0m x 9.5mm)	15-1/8	384.2	5-5/8	142.9	9	4.1

Pneumatic seal-feed combination tool specifications

AMPT-12	422910	Up to 400 lbs.	Pneumatic Combination	Contrax 816, 818 Dymax 502, 504, 506, 508 Tenax 1816, 1818, 1822	Triple Crimp	50 ASD	Unlimited	4-1/2	114.3	Air	Part No. 008558 10' x 3/8" (3.0m x 9.5mm)	9.0	228.6	13.5	342.9	21.5	9.8
AMPT-58	422200	Up to 600 lbs.	Pneumatic Combination	High-Strength Tenax 2030, 2038B, 2040	Triple Crimp	58 AMT	Unlimited	4-1/2	114.3	Air	Part No. 008558 10' x 3/8" (3.0m x 9.5mm)	9.0	228.6	13.5	342.9	21.5	9.8

Plastic/Suspension systems & accessories

3610 W. Lake Ave. • Glenview, IL 60025
1-800-323-2464 • www.signode.com

Suspension systems for combination tools

Balance arms

A balance arm counterbalances a strapping tool so that only a light touch by the operator will move it where needed. The base of the tool remains parallel to the strapping surface. The AST combination tool uses the Model BA-16A balance arm (Part No. 005705) and adaptor (Part No. 008694). The AMPT combination tool uses the Model BA-21A balance arm (Part No. 005630) and adaptor (Part No. 020745).

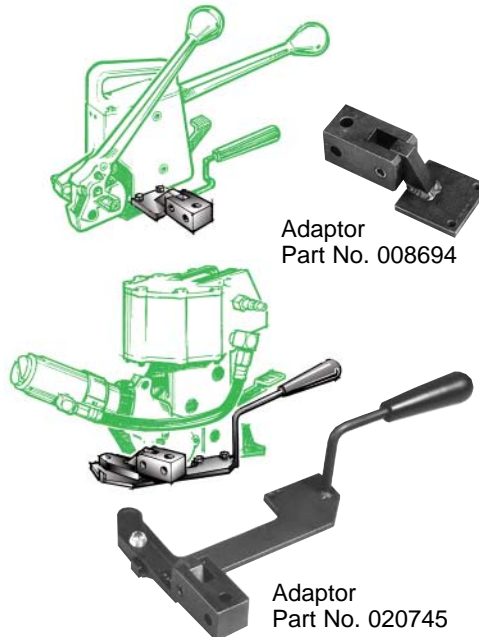

Overhead tool balancers

Tool balancers are the easiest and most efficient way to suspend strapping tools from a fixed ceiling bracket, monorail, jib or bridge crane.



BFL-13

Part No. 306809*
9-13 lbs. (4.1-5.9 kg),
6.6 ft. (2 m) cable travel



EB2500R

Part No. 485001*
18-25 lbs. (8.2-11.4 kg),
6.6 ft. (2 m) cable travel



EB4500R

Part No. 485003
35-45 lbs. (15.9-20.5 kg),
6.6 ft. (2 m) cable travel

EB3500R

Part No. 485002*
25-35 lbs. (11.3-15.9 kg),
6.6 ft. (2 m) cable travel

D655

Part No. 005597
Hose reel (with ratchet lock and hose) for pneumatic tools, 35 ft. (10.7 m) length of travel



Pneumatic tool accessories

All new Signode® pneumatic tools are supplied with a quick-disconnect plug. A filter and regulator are needed with all Signode pneumatic sealers. A filter-regulator-lubricator is needed with pneumatic tensioners and combination tools. These additional fittings and air hoses are available from Signode to provide efficient installation.

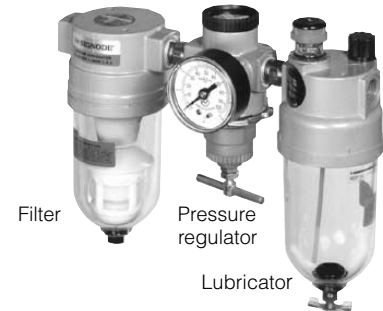

Filter-Regulator-Lubricator assembly
(Part No. 173111)



Regulator mounting bracket
(Part No. 071982).



Y-fitting
(Part No. 008574).
For operating two tools simultaneously.



Quick-disconnect socket
3/8" (9.5mm) i.d.
(Part No. 008569).
Lubricator fitting for hose connection.



Quick-disconnect socket
1/4" (6.4mm) i.d.
(Part No. 020706). Hose fitting for tool connection.



Quick-disconnect plug
1/4" (6.4mm) i.d.
(Part No. 008568). Hose fitting for lubricator connection.



Quick-disconnect plug
1/4" (6.4mm) i.d.
(Part No. 020704).
Tool fitting for hose connection.

Recommended Air Hoses for Pneumatic Tools

Minimum requirement: 10' x 3/8" (3.0m x 9.5mm) i.d. (Part No. 008558).
Recommended hose: 10' x 1/2" (3.0m x 12mm) i.d. (Part No. 424774).

Note: Use light hydraulic oil in lubricator, such as Non-Fluid Oil No. LS-1236 (Part No. 008556) or equivalent.