

New!

SIGNODE LB-2300™

• SERIES •

Automatic and Semiautomatic
plastic strapping machines

**Jam-resistant
technology**

**52 straps
per minute**

**Automatic
cut-off and
refeed option**



LB-2300™
Semiautomatic
strapping
machine

SIGNODE®



A new generation of strapping systems from Signode

Signode Packaging Systems introduces the LB-2300™ Series plastic strapping machines with the highest available speed, most reliable performance and lowest maintenance operation of any general-duty strapping machine on the market today. Whether your operation requires a semiautomatic or fully automatic strapping system, the LB-2300 Series machines increase production speed, reduce operator involvement and simplify service functions to save you time and money.

Jam-resistant technology

The LB-2300 Series strapping machines are designed to deliver the most jam-resistant technology available.

Unequaled speed

Cycling up to 52 straps per minute, the LB-2300 Series strapping machines are the fastest machines in their class.

Automatic loading

Two simple steps:

1. Lift the lever and insert strap into the slot.
2. Push the cycle button. The machine threads itself and is ready to go.



Automatic cut-off and refeed option

Unlike other automatic strapping machines that require an operator to clear strap jams, the Signode LB-2300 Series (using Signode's patented automatic cut-off and refeed option) automatically ejects misfed strap, rethreads itself and continues strapping without operator intervention. Equipped with this option, the automatic model becomes a truly operatorless machine.



Fully accessible strap path

Machine and strapping guides are easily opened, providing complete access to the strap path in less than 20-seconds without using any tools.



Lubrication-free operation

The LB-2300's and 2330's self-lubricating design provides excellent durability and maintenance-free operation.

The Signode System

Since 1913, the name Signode has meant reliable, durable, high quality protective packaging systems that improve your package, protect your product and increase your profits.

When you buy from your Signode distributor, you get top quality products made in the U.S.A., plus a local network of service and sales representatives to meet your ongoing packaging needs



Your Signode distributor sales representative can visit your plant, test alternative solutions, document cost versus savings and recommend appropriate products.

Your local Signode distributor service person will provide you with supervised installation and start-up, updated technical information, operator and maintenance training, scheduled overhaul programs, emergency service and spare parts

LB-2330™

Automatic strapping machine

Shown with optional compression module

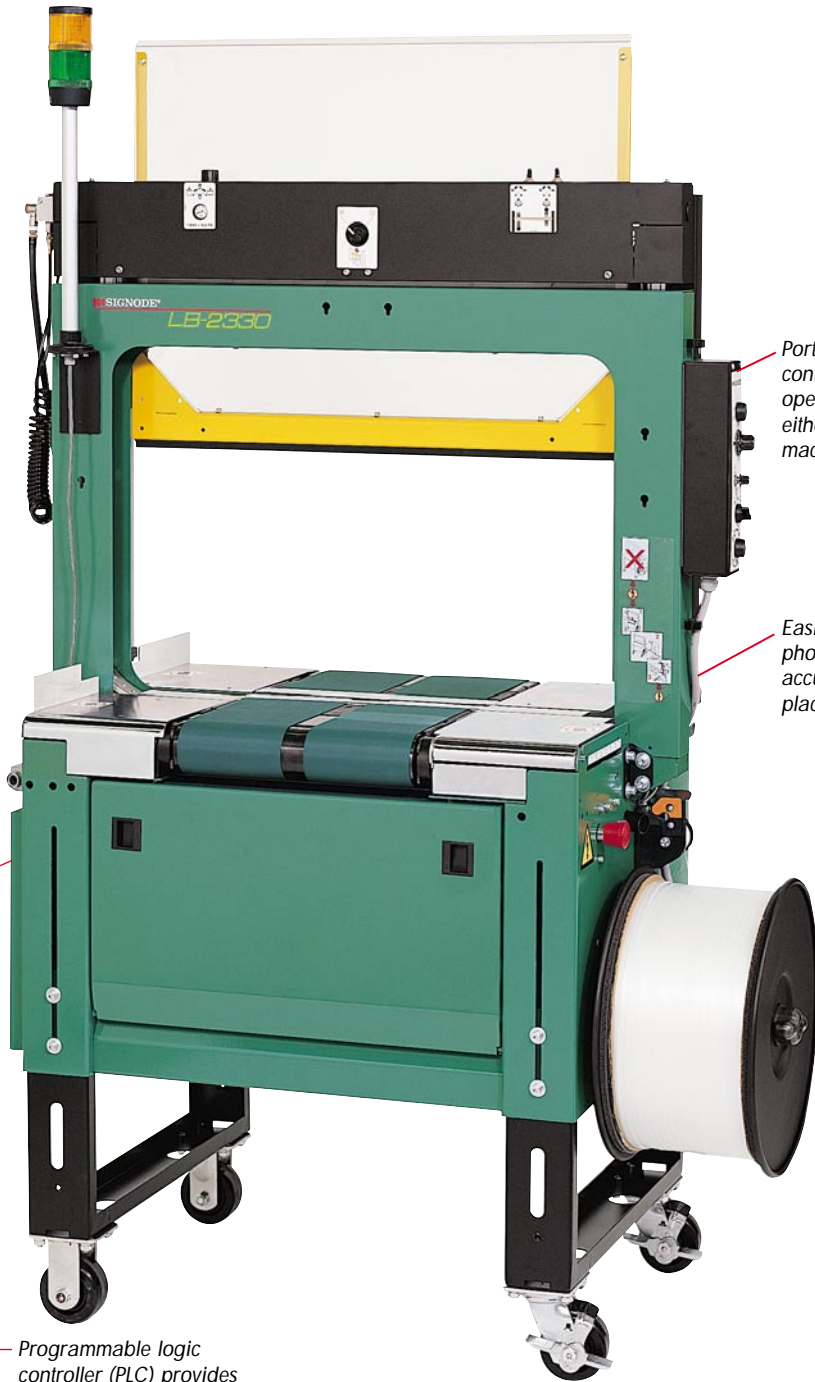

Portable operator controls facilitate operation from either side of the machine.

Easily adjustable photo eye insures accurate strap placement.

Programmable logic controller (PLC) provides easy troubleshooting.



Options

LB-2300 and LB-2330 models

■ Single or dual compression*

Top compression (up to: 120 lbs at 90 PSI, single compression; 240 lbs at 90 PSI, dual compression) settles over-packed containers, closes telescoping cartons or stabilizes bundles of loose items.

■ Automatic cut-off and refeed*

■ Low strap kit/ Indicator light*

A photo eye, mounted on the machine, detects low strap conditions. The indicator light alerts operators to both low strap conditions and machine malfunctions.



■ Foot cycle switch

Activates strap cycling for flexible operation.



■ Mushroom cycle button

Can be positioned on either side of the chute for the most convenient strap cycle activation.



LB-2300

Semiautomatic model only

■ Roller top

LB-2330

Automatic model only

■ Conveyor interlock kit

Synchronizes machine conveyor with your present handling system.

■ Multiple strap function

Enables you to automatically place three or more straps on a package.

*These options are not available on single phase, 120 volt machines.



Contrax® plastic strapping

Enhance the quality and performance of your LB-2300 Series strapping machine with Signode Contrax® polypropylene strapping.

- Consistent width and gauge control
- Smooth, uniform surface
- Resists splitting
- Recovers when elongated
- Recyclable (ask about Signode's recycling program)

LB-2300/LB-2330 Specifications

Models

LB-2300 Semiautomatic

LB-2330 Automatic

Production rate

Up to 52 straps per minute in a 17"W x 20"H chute. Actual production will vary depending on package size, chute size and operator dexterity. A cycle counter is standard on all models.

Chute size

See chart and illustration on right

Maximum package weight

100 lbs on machine or conveyor. May increase depending upon weight distribution.

Strapping

5mm or 6mm polypropylene strapping.

Strap tension

Adjustable up to 60 lbs

Machine dimensions (largest chute size)

Small Frame: 670mm L x 1250mm W x 1830mm H (26-1/2" x 49" x 72"), maximum height without optional height kit.

Large Frame: 670mm L x 2425mm W x 1535mm H (26-1/2" x 95-1/2" x 60-1/2"), maximum height without optional height kit.

Tabletop height

Adjustable 685 to 940mm (27" to 37").

Optional height kits: 660 to 915mm or 915 to 1165mm (26" to 36" or 36" to 46").

Electrical requirements

115 volt, 60Hz (semiautomatic only);

230 volt, 60Hz; 460 volt, 60Hz

Shipping weight

550 lbs

Small frame

Chute inner dimensions

	Small chute		Medium chute		Large chute	
	mm	inches	mm	inches	mm	inches
A	430	17	710	28	840	33
B	510	20	510	20	760	30

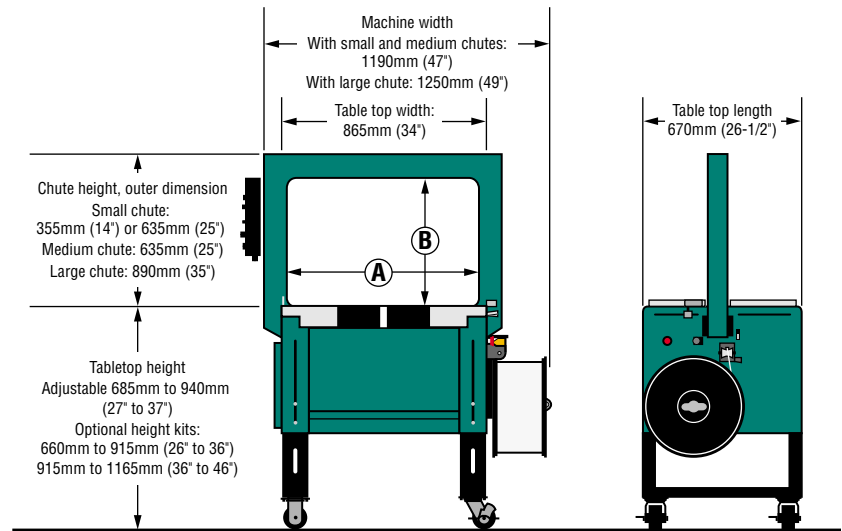

Large frame

Chute inner dimensions

	Small chute		Medium chute		Large chute	
	mm	inches	mm	inches	mm	inches
A	1219	48	1219	48	1651	65
B	610	24	1219	48	508	20

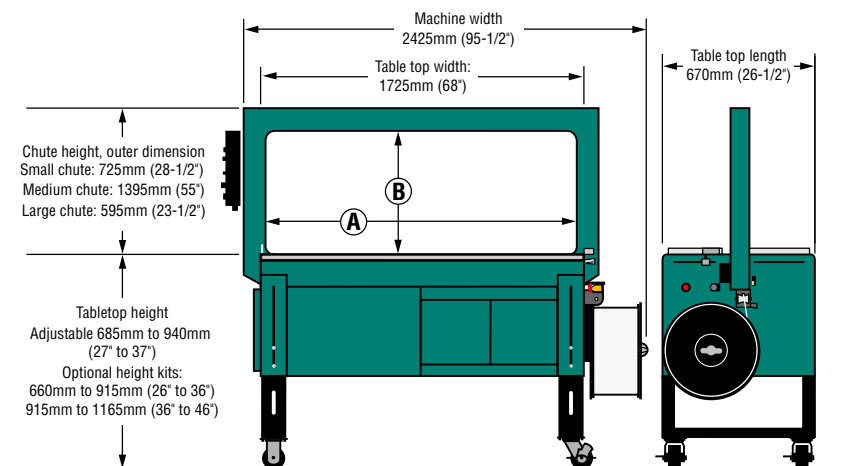

180 Hastings Dr
Buffalo Grove, IL 60089-6989
800.526.1948